

Application and Description

The F/I(U)-Converter transforms a frequency signal into a standardised output signal from 0...20mA, 4...20 mA or 0...10VDC. The converter provides the standardised signal for control systems, PC based data monitoring, recorders or display instruments. The F/I(U)-Converter series 587 has

- very good linearity
- high temperature stability
- and especially high long-term stability

so that very good reproducibility is attained.

Frequency signals from different speed sensors, encoders or proximity switches with NPN, PNP, push-pull or TTL output can be processed as well as sinus-shaped signals from passive sensors (magnetic pick-up).

The frequency signal is separated galvanically by means of an optocoupler and led to the microcontroller. By means of a very precise measuring technique the frequency is converted to a data string and linked to the set alignment factor in order to trigger the D/A converter. Very good linearity is attained with the D/A converter, with a resolution of 12 bits and with the measuring technique, itself.

The output signal of the D/A converter is transformed into the standardised signal via a precise output stage. Since the transformation is almost exclusively dependent on the quartz frequency and the reference of the D/A converter, very good temperature criteria and excellent long-term stability are attained.

The parameters measuring time and frequency, which are important for RPM measurement, can be programmed so that, for example, an uneven run in combustion engines can be

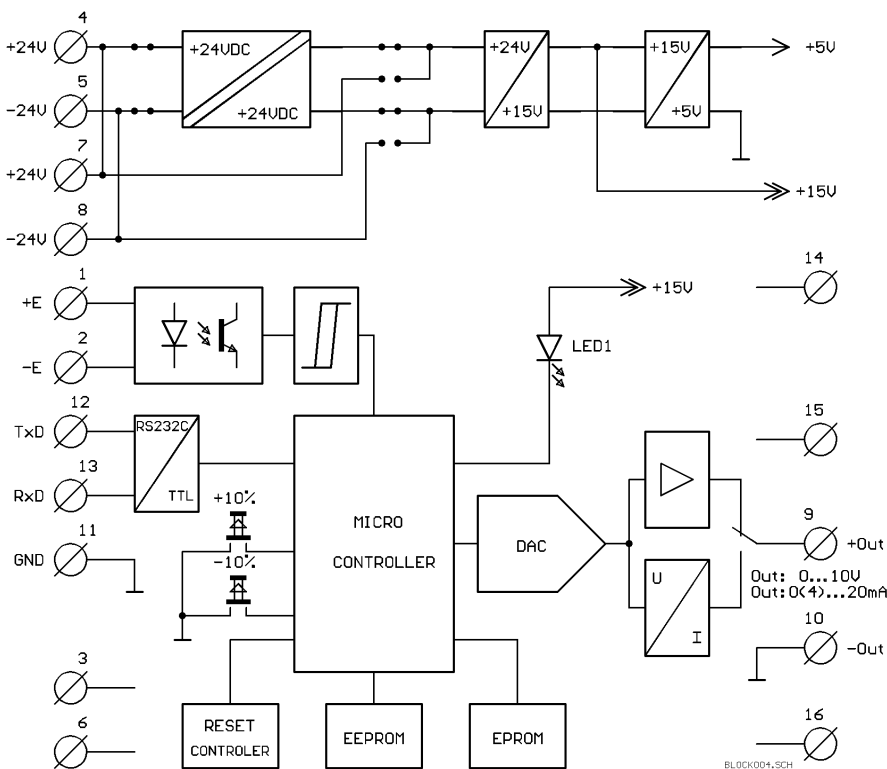

Type 5873 with galvanic separation of power supply

over-rided by the programm setting. There is a version available, with galvanic separation of supply for the application at diesel engines on ships.

Programming

The converter can be programmed with the help of a PC software (Windows 95 or higher) to meet the special requirement of the respective measuring task.

- Output can be configured as a 0...20mA, 4...20mA or 0...10V standardised signal.
- The appropriate frequency value can be set between 25 and 18.000 Hz.
- Any frequency between 0% and 50% of the maximum value can be set as zero point.
- Measuring time and the number of measuring periods can be chosen.
- Erratic changes can be attenuated by means of a delay function.

The parameter set-up can be done by the manufacturer or by the user. If the set-up is done by the manufacturer the user can carry out a final alignment of the converter. The final alignment of the converter (+/-10%) can ensue at any local frequency by means of a frequency generator (stable frequency) or directly on the machine itself. For this purpose there are two keys which are protected against being used accidentally. A functional LED shows the respective operating situation of the converter.

Triggering with various sensors

Different types of sensor (speed sensors, encoders, proximity switches, etc.) can be attached to the converter. Signal requirements must be considered with passive magnetic pick-ups.

Signal Input:	Frequency range: 0...18.000 Hz Signal: separated by optocoupler Internal resistor: 2,2kOhm Current (on): $I_F = 1,0 \text{ mA}$ $U_e > 4, \text{VDC}$ Current (off): $I_F = 0,2 \text{ mA}$ $U_e < 1 \text{VDC}$ Voltage: $U_e(\text{max}) \pm 32 \text{ VDC}$ Signal types: NPN-, PNP-type speed sensor, encoder or proximity switches Magnetic pick-up sinus signal Generator sinus or rectangle signal
----------------------	---

Ansteuerung mit PNP-Ausgang

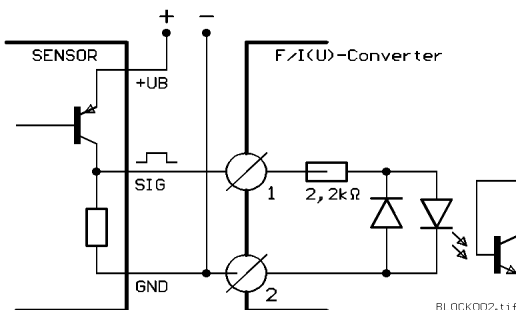

Ansteuerung mit NPN-Ausgang

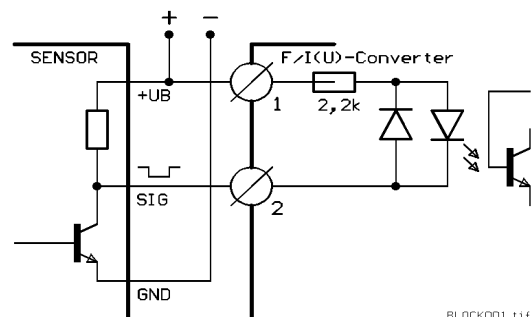

Ansteuerung mit magnetisch-induktivem Sensor

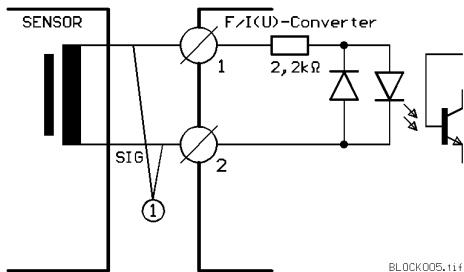

BLOCK005.tif

Signalanforderungen

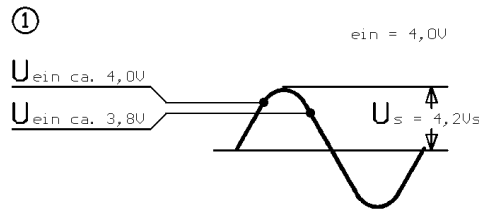

Mindestanforderungen $U_s = 4,2V$
 $U_{eff} = 3,0V$

Signalbelastung durch den
F/I(U)-Converter
Eingangswiderstand $R_i = 2,2k\Omega$

BLOCK006.tif

Standardised Output Signal

The output signal can be programmed by means of a software to fit the respective measuring job. When doing this it is necessary to establish which standardised signal is required, and which lower and upper frequencies correspond to the minimum and maximum analogue values. After programming an additional final alignment of +/-10% can be performed directly on the instrument.

Output: (programmable)	Current:	0...20mA 4...20mA
	Voltage:	Load: max. 500 Ohm Limitation: 22mA
		Current: max. 30mA
	Time constant: Final alignment:	+17ms +/- 10 %

The reaction time of the output is determined by the programmed period count (P) and the calculating time of the controller. 17ms after the n+1st rising signal edge is recognised the analogue value appropriate to the frequency is then at the output.

Operation:	LED on:	Converter in operation
	LED flashing:	Converter in programming mode
	LED off:	no power supply or error
Final alignment of the installed converter by two protected keys. Programming can be done by manufacturer or user.		

The high definition and the choice of components permits very precise conversion of the frequency signal to the analogue signal. Overall precision depends mainly on the number of scanning cycles, calculation precision of the processor and the definition of the D/A converter. In order to use the high precision of the converter to the full, it is necessary to calculate the period count and to set the device accordingly. The calculation formula is as follows:

$$\text{Period Count (P)} > \text{max. frequency (F}_{\text{max}}) / 100$$

In this way a scanning precision better than 0.01% is ensured. Further increase of period count improves scanning precision and thus overall precision.

Accuracy:	Definition:	12 Bit
	Linearity:	+/- 0,1%
	Zero alignment:	0,002V (Operating mode 0...10VDC) 0,01mA (Operating mode 0(4)...20mA)
	Temp.coefficient:	0,05 % (10K)
	Long-term stability:	0,1% (p.A.)

Increasing period count enables very good overall precision. By means of the programmable period count, system related speed anomalies within one or more rotations, for example with combustion engines, can be compensated for. In such applications the period count should be selected so that it corresponds to the number of impulses of one complete rotation or several thereof.

Period Count (P) = Number of impulses per rotation x n
AND
Period Count (P) > max. frequency (F_{max}) / 100

Measuring time is determined by the choice of period count. In order to receive an update of the analogue output signal within a certain measuring time, the measuring time can be limited to the range of 50 to 5000ms. This ensures that changes in frequency within a prescribed time range are recognised even if not all impulses necessary for the calculation are available.

Delay Funktion (PT1)

For the incorporation of the converter into control circuits the time constant (T1) can additionally be programmed in the range of 0 to 5000 ms. This results in a logic function corresponding to the proportional function of first order delay (PT1). In this way jumps in frequency, which should not to lead to a strong change in the analogue immediately (i.e. after 17ms of calculating time), can be smoothed. The effects of the time constants T1=0 and T1=100ms are shown in the following graphs:

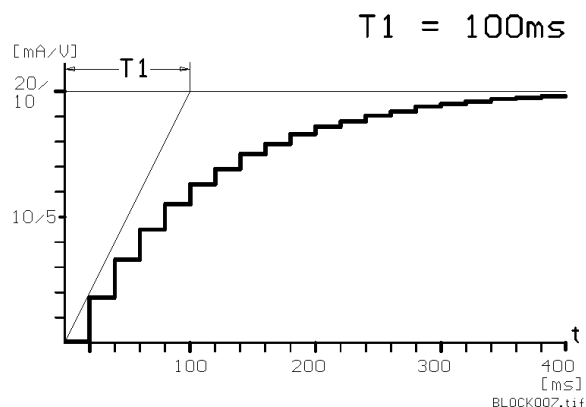
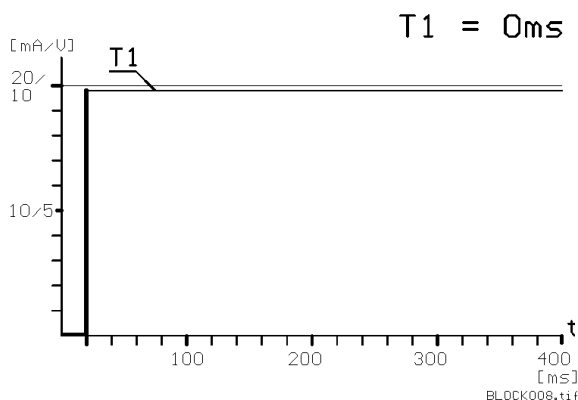

General Technical Data

Power Supply:	Voltage:	18...32 VDC (Type 5873 with galvanic separation) (Type 5870 without galv. separation)
	Current consumption:	Type 5873 150mA at output current 20mA Type 5870 90mA at output current 20mA
Temperatur Range:	Operating Temp.:	-20°C...+60°C
	Storage Temp:	-25°C...+85°C
Mechanical Data:	Housing:	glass fibre reinforced plastic; polycarbonat
	Mounting:	DIN rail (DIN 46277)
	Dimension (mm):	43x70x144 (BxHxT)
	Connection:	Screw in terminal blocks max.1,5mm ²
	Protection Code:	IP20
	Weight:	0,2kg
Guarantee:	12 months	
Standards:	Declaration of Conformity acc. EC-Rule 89/336 EWG (CE-Sign)	
	EMC-Immunity	acc. DIN EN 50082-1:1992-01; Part 2 and DIN EN 50082-2:1996-02; Part 2
	EMC-Emmision	acc. EN 55011:1992-07

Connection Set-Up

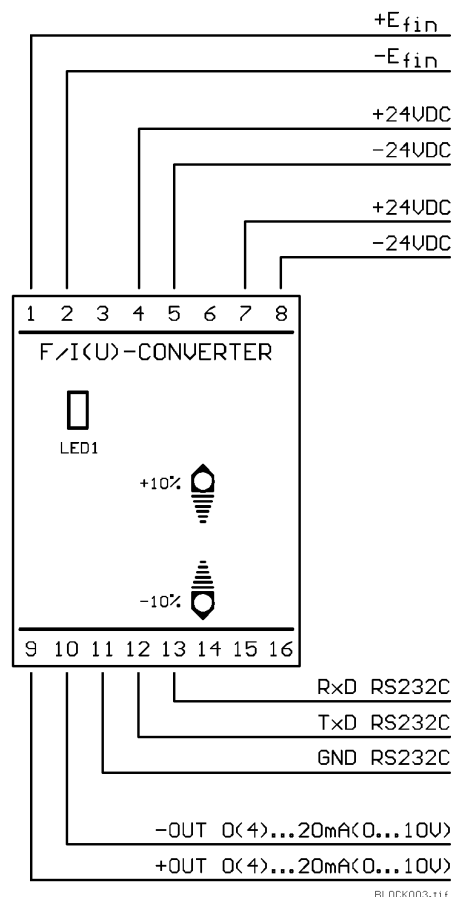

We recommend that the power supply be connected to terminal 7 and 8. If the sensor should be powered from the same source, then the supply (+UB) of PNP sensors is to be connected to terminal 4 or the ground (GND) of NPN sensors to terminal 5.

Terminals 4 and 5, for the supply to the sensors, are connected internally in parallel to terminal 7 and 8 (see block circuit diagram).

For use in diesel engines for ships we would recommend the devices with galvanic separation.

EMC Immunity is according to the EC guidelines. The offset is below 1%. With regard to use in the ship area stricter conditions (compared to normal industrial standards) were put into application.

Types and Prices

With regard to the series 587 converter, it has to be decided whether the devices have to be equipped with galvanic separation of the supply or not.

Part Number	Scope of delivery
5870.001	F/I(U)-Converter without galvanic separation; no customized settings
5870.401	F/I(U)-Converter without galvanic separation; including customized settings
5873.001	F/I(U)-Converter with galvanic separation; no customized settings
5873.401	F/I(U)-Converter with galvanic separation; including customized settings
Additional order information:	<p>When types 5870.401 and 5873.401 are ordered we require the following additional information, in order to set the devices accordingly at our plant:</p> <ul style="list-style-type: none">• <u>Output:</u> 0...20mA or 4...20mA or 0...10VDC;• <u>Max. Frequency:</u> 25...18.000Hz• <u>Min. Frequency:</u> 0...50% of max. frequency in Hz• <u>Period Count:</u> 1...255 impulses per revolution• <u>Max. Measuring time:</u> 50...5000ms• <u>Time Constant T1:</u> 0...5000ms <p>If there is no information about the minimum frequency, period count and measuring time available then we use the standard values 0Hz; 15; 2000ms and 0ms.</p>
	Software for programming the F/I(U) converter, including operating manual, can be downloaded from our homepage